

# SWIMMING POOL HEAT PUMP UNIT

## Installation & Instruction Manual

### Applicable for:

P- Model

PC- Model

AC- Model

1. Please read this manual carefully before you install the product. Failure to do so may lead to damage of the heat pump or injury to operators as well as cause financial loss.

2. Scientific and technological developments may lead to product improvements as well: please check with us regularly to ensure that you are up to date with the latest product developments.

3. If you need any further technical information, please contact your local distributor.

4. Attention:

4.1 Before installing the heat pump, please check whether the local power supply corresponds with the requirement of the heat pump. For details, refer to the label on the unit or performance data in this manual.

4.2 Please install the electrical protection devices according to the local regulations.

4.3 Connecting the heat pump to a ground wire is necessary in order to prevent electrical shock caused by an unexpected short circuit inside the unit.

4.4 An electrical wiring diagram is provided in this manual.

4.5 For safety reasons, please do not change or repair the heat pump by yourself. If it is necessary, please contact your local distributor for help.

4.6 Do not put any objects into the heat pump when running as these may touch the fan and damage it or lead to accidents (particularly for children).

4.7 Do not use the heat pump without the grid or plate work since it may lead to accidents or abnormal operation of the unit.

4.8 If the unit is soaked in water, please contact your local distributor immediately. The unit can only be restarted after a thorough inspection by professional technicians.

4.9 Unqualified technicians are not allowed to adjust any switches, valves or controllers in the unit.

## Contents

### 1. Performance data and installation

1.1 Performance and features.....	5
1.2 Working principles .....	5
1.3 Where to install the heat pump.....	6
1.4 Distance from the pool.....	7
1.5 Installation of the check-valve.....	8
1.6 Pool system set up .....	9
1.7 Connecting the by-pass .....	9
1.8 Electrical connection.....	10
1.9 First time start-up .....	11
1.10 Condensation .....	11

### 2. Controlling the heat pump (LCD)

Only for LCD Display - not applicable.

### 3. Controlling the heat pump (LED)

3.1 Controller diagram .....	12
3.2 How to start heat pump .....	12
3.3 How to change mode .....	13
3.4 How to set desired water temperature .....	13
3.5 How to change parameter setting - <b>ONLY FOR DEALERS</b> .....	13
3.6 How to check parameter setting & measured values of current status .....	14
3.7 How to set the clock .....	15
3.8 How to set timer start and timer stop .....	16
3.9 How to cancel timer start and timer stop .....	16
3.10 Keypad lock and unlock .....	16

### 4. Protection systems

4.1 Water flow switch .....	17
4.2 Refrigerant gas high and low pressure protection .....	17
4.3 Overheating protection on the compressor .....	17
4.4 Automatic defrost control .....	17
4.5 Temperature difference between in-flowing and out-flowing water .....	17
4.6 Low temperature cut-off .....	17
4.7 Anti-frost protection during winter .....	17
4.8 First anti-frost protection .....	17
4.9 Second anti-frost protection .....	18

### 5. Recommendations

5.1 Swimming pool water chemistry .....	18
5.2 Heat pump winterizing .....	18
5.3 Restarting the pump after winter .....	19
5.4 Check-up .....	19

### 6. Maintenance and inspection

6.1 Maintenance .....	27
6.2 Troubleshooting guide .....	27
6.3 Overview of failure code on display (LCD CONTROLLER) - only for LCD - not applicable.....	30
6.4 Overview of failure code on display (LED CONTROLLER) .....	30
6.5 Failure code table for Chiller-300 three phase .....	31
6.6 Failure code table for Protect 300 .....	33
6.7 Failure code table for general PCB (single-system) .....	34
6.8 Failure code table for general PCB (dual-system)- only for dual-system- not applicable.....	35

### 7. Name plate & wiring diagram

7.1 Name plate - not applicable.....	35
7.2 Wiring diagram - not applicable.....	35

## 1. Performance and Installation

### 1.1. Performance and Features

High Efficiency

With a COP value up to 5.0, our heat pumps are very efficient when transferring heat from the air to the swimming pool water. You can save as much as 80% of cost compared to an electrical heater.

Long lifespan

The heat exchanger is made of PVC with titanium tube, which enables it to withstand prolonged exposure to swimming pool water.

Easy control and operation

The unit is very easy to operate: simply switch it on and set the desired pool water temperature. The system is equipped with a micro-computer controller, allowing all operating parameters to be set. Operation status can be displayed on the controller with LED display.

### 1.2 Working Principles

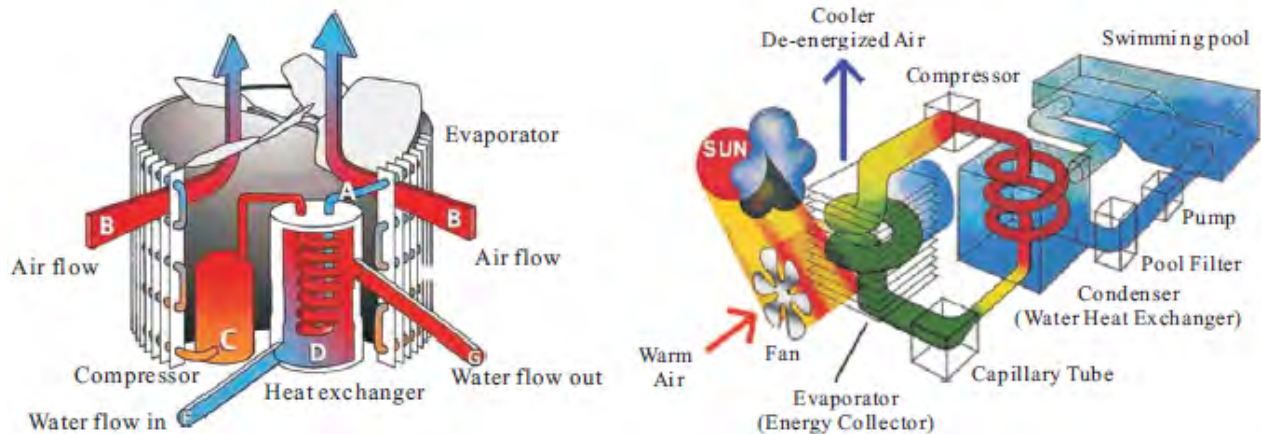

Heat pumps use heat from the sun by collecting and absorbing energy from the outside air. This energy is then compressed and transferred to the pool water. Your existing water pump circulates the water through the heat pump, which is normally installed next to the pool filtration system, and the water warms up. The heat pump timer can be set so that the pump operates at the times you want: for example, during daylight hours from 9am to 5pm.

- The unit contains a fan that draws in outside air and directs it over the surface of the EVAPORATOR (energy collector). The liquid refrigerant inside the EVAPORATOR coil absorbs the heat from the outside air and becomes a gas.
- The warm gas inside the coil passes through the COMPRESSOR, which concentrates and increases the heat to form a very hot gas, which then passes through the CONDENSER (water heat exchanger). It is here that the heat exchange occurs as the

heat from the hot gas is transferred to the cool swimming pool water circulating through the heat exchanger.

- The pool water becomes warmer and the hot gas returns to its liquid form as it flows through the CONDENSER coil. The gas then passes through the CAPILLARY TUBE and the whole process begins again.
- Developments in heat pump technology mean that today heat pumps can efficiently collect heat from the outside air even when the temperature is as low as 7-10°C. This means that for tropical and subtropical climates the pool can be maintained between 26°C and 32°C.

### 1.3 Where to install the heat pump

The unit will perform well in any location as long as the following are available:

- Fresh air
- Electricity
- Pool filtration piping

The unit can be installed almost anywhere outside provided the minimum distance requirements with respect to other objects are met (see diagram below). For indoor pools, please seek advice from your installer. If the unit is placed in a windy area, there are no problems with the pilot light as is often the case with gas heaters.

Warning: Do not place the unit in an enclosed area with a limited air volume where the air discharged by the unit will be re-circulated or near shrubs that could block the air inlet. Installation in such locations will deny the unit a continuous supply of fresh air, which will reduce its efficiency and may prevent adequate heat yield.

See diagram below for minimum distance requirements:

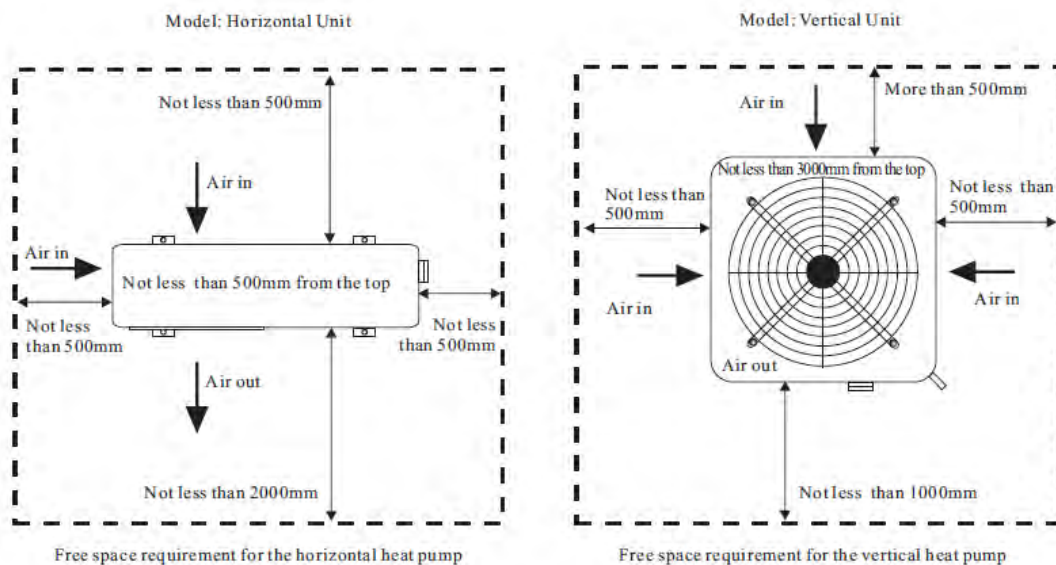

#### Warning:

- Do not place your hand or any other objects into the air outlet and fan. It could damage the heat pump and cause injuries;

- In case of any abnormality with the heat pump, cut off the power immediately and contact a professional technician;
- It is strongly advised to place a protective guard around the unit to keep children away from the heat pump.

#### **1.4 Distance from the pool**

Normally, the heat pump is installed within a 7.5m radius of the pool. The greater the distance from the pool, the greater will be the heat loss from the piping. Since the piping is buried for the most part, heat loss is minimal for distances up to 15m between pump and pool (total to and from pump:  $15\text{m} \times 2 = 30\text{m}$ ), unless the soil is wet or the water level is high. Heat loss per 30 metres could roughly be estimated at 0.6kw-hour (2000BTU) for every 5°C temperature difference between the pool water and the soil surrounding the pipe, which translates into an increase in operating time of 3-5%.

### 1.5 Installation of check-valve

Warning: When using automatic chlorine and pH dosing systems, it is of utmost importance to protect the heat pump from high concentrations of chemicals as they could corrode the heat exchanger. It is therefore recommended that these systems should add the chemicals into the pipes located **DOWNSTREAM** (after) of the heat pump, and it is also recommended that a check-valve be installed in order to prevent backflow when there is no water in circulation.

Damage to the heat pump caused by disregarding any of these recommendations will invalidate the warranty.

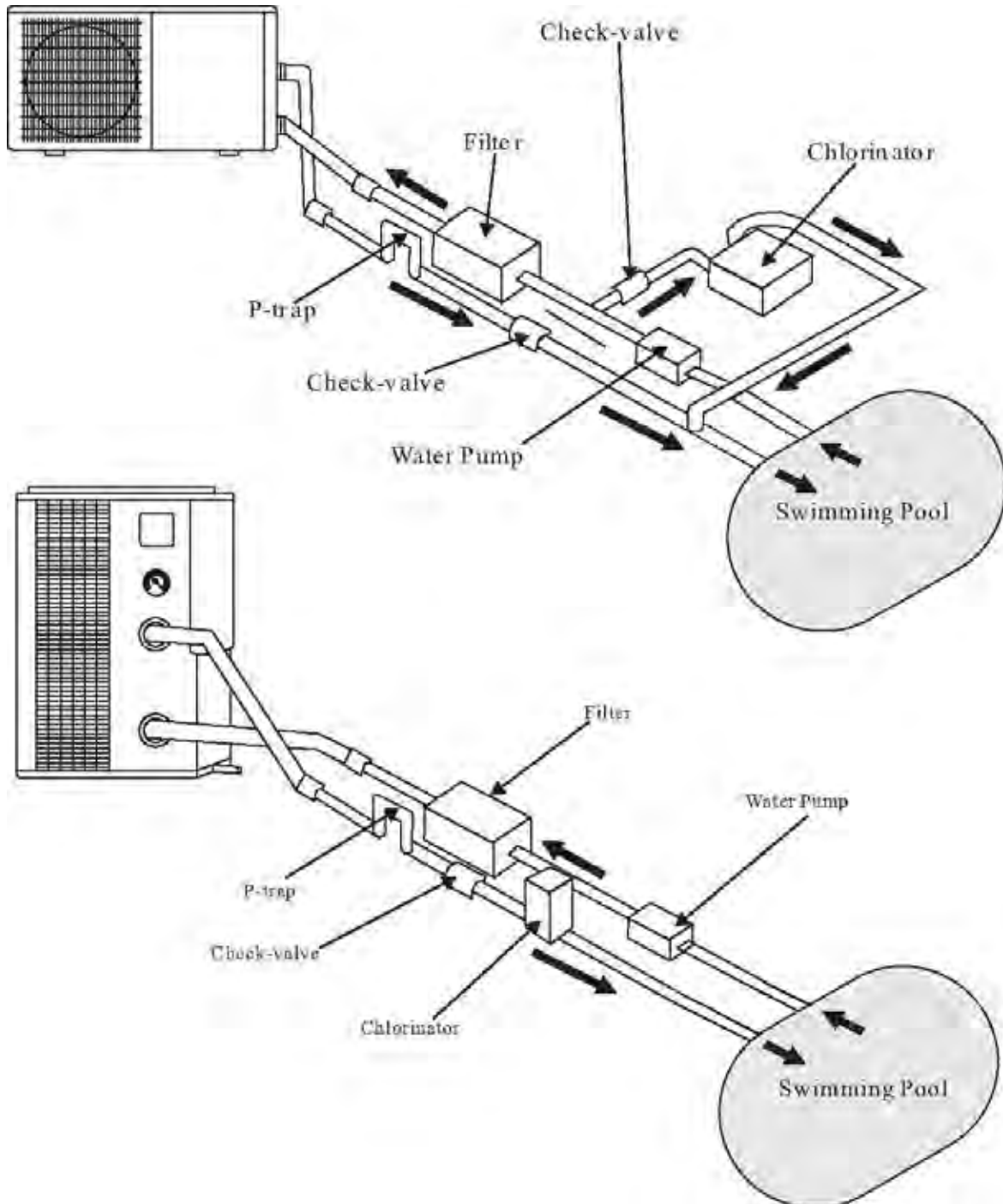

### 1.6 Pool system set up

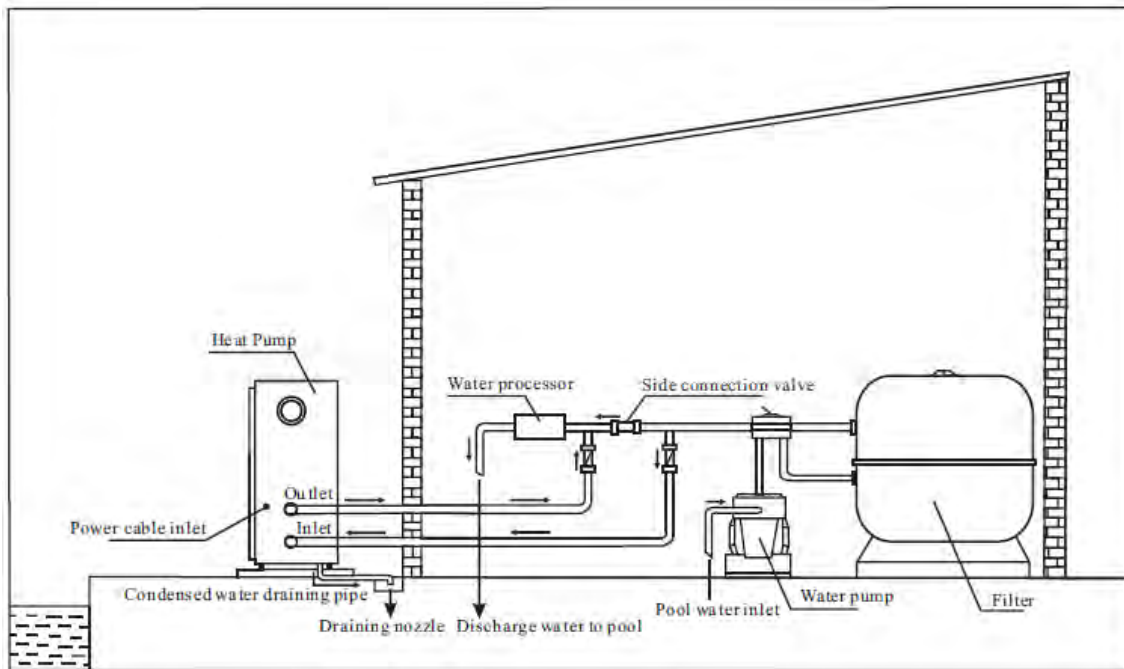

### 1.7 Connecting the by-pass

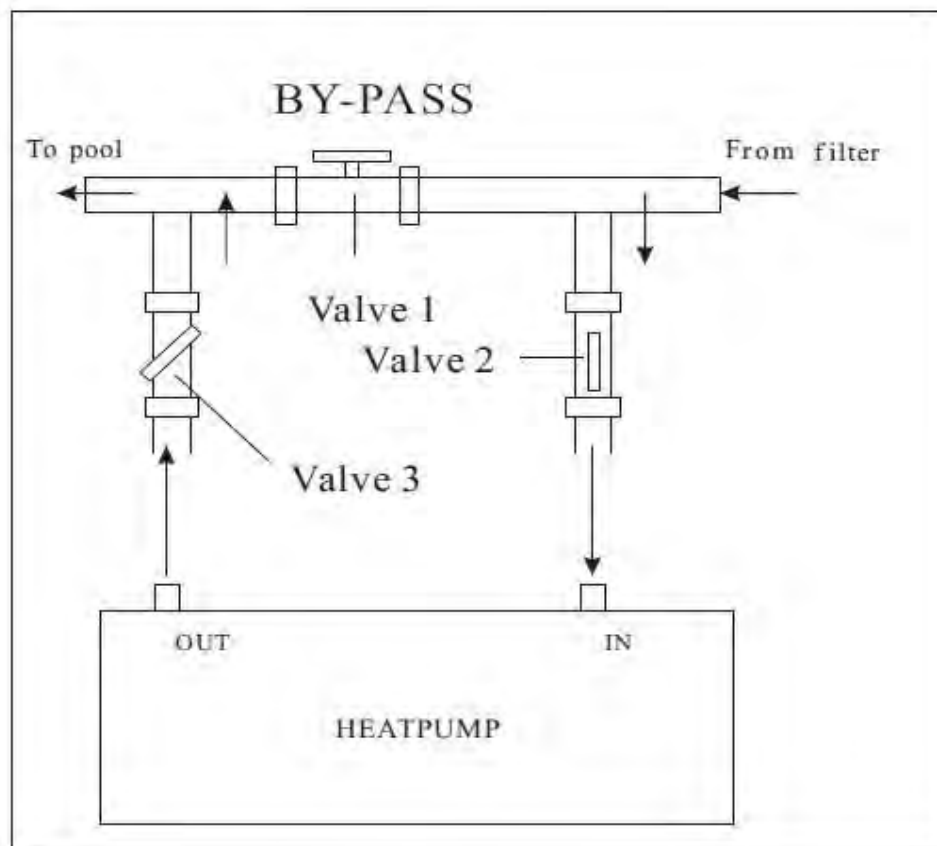



## 1.8 Electrical Connection

**Important** – although the heat pump is electrically isolated from the rest of the unit, this only prevents the passage of water to or from the pool water. It is still necessary to ground the unit to protect yourself from short circuits inside the unit. Make sure there is an adequate ground connection.

Check if the voltage of the electrical mains corresponds with the operating voltage of the heat pump prior to connecting the unit.

It is recommended to use a separate fuse (slow-type D-curve) as well as adequate wiring (see table below).

For horizontal models: remove the panel on the right of the fan opening.

For vertical models: remove the curved panel on the front side.

Connect the terminal wires with the terminal block labelled 'Power Supply'. Next to this connection there is a second terminal block labelled 'Water Pump', to which the filter pump (max 5A / 240V) can be connected. This connection makes it possible to control the filter pump operation with the heat pump. See the Parameter Setting Table below (Parameter 9) for other possibilities.



**Remarks:** for models with 3 phases, switching 2 phases may cause an inversion of the rotational direction of the electrical motors, which could damage the unit. Therefore, a protection device has been built in, which will interrupt the circuit if the connection has not been carried out correctly.

Model	Voltage (volt)	Fuse T3/ slow blow (A)	Nominal current (A)	Cable diameter (mm <sup>2</sup> ) (for max. Length of 20 meters)
P5/ PC6	220 - 240	10	3.9	2x2.5 mm <sup>2</sup> + Ground
P6/ PC8/ AC6P	220 - 240	10	4.55	2x2.5 mm <sup>2</sup> + Ground
P8/ PC10/ AC10P	220 - 240	16/ 13	6.64	2x2.5 mm <sup>2</sup> + Ground
P10/ PC13/ AC13P	220 - 240	16/ 13	7.87	2x2.5 mm <sup>2</sup> + Ground
P13/ PC15/ AC15P	220 - 240	16/ 13	9.78	2x2.5 mm <sup>2</sup> + Ground
P15/ PC17/ AC17P	220 - 240	20/ 16	11.03	2x2.5 mm <sup>2</sup> + Ground
P17/ PC20	220 - 240	25/ 20	14.88	4x2.5 mm <sup>2</sup> + Ground
P21/PC25/AC25P	380- 400	16	6.36	3x2.5 mm <sup>2</sup> + Ground
P25/PC30	380- 400	16	7.42	3x2.5 mm <sup>2</sup> + Ground

## 1.9 First-time start-up

**Note: in order for the unit to heat the pool (or spa), the filter pump must be running so that the water can circulate through the heat pump. Without this circulation, the heat pump will not start.**

When all connections have been made and checked, the following steps should be followed:

1. Turn on the filter pump. Check for leaks and verify that there is a flow to and from the pool.
2. Turn on the electrical power supply to the unit, then press the ON/OFF key on the electronic control panel. The unit should start when the time delay period has lapsed.
3. When the unit has been running for a couple of minutes, check if the air leaving the unit is cooler.
4. Check the performance of the flow switch as follows: with the unit running turn the filter pump off. The unit should also switch off automatically. If not, the flow switch must be readjusted.
5. The unit and the filter pump should run 24 hours a day until the desired pool water temperature has been reached. Once the set temperature is reached, the unit will switch itself off. As long as the filter pump is running, the unit will restart automatically when the temperature of the pool water drops more than 1°C below the set temperature.

Depending on the starting temperature of the pool water and the air temperature, it can take several days for the water to reach the desired temperature. Covering the pool with a pool cover can reduce this period significantly.

**Water flow switch:** the unit is equipped with a flow switch that switches on when enough water flows through the unit and switches off when the water flow becomes too low (e.g. when the filter pump is switched off).

**Time delay:** the unit is equipped with a built-in 3-minute start delay to protect electrical components and contacts. After this time delay, the unit will automatically restart. Even a brief interruption in the power supply will activate the start delay and prevent the unit from starting immediately. Additional interruptions of the power supply during the delay period will have no effect on the 3-minute countdown.

### **1.10 Condensation**

When the swimming pool water is being heated by the heat pump, the incoming air is cooled down considerably, which can cause condensation on the fins of the evaporator. Condensation volumes can reach several litres per hour under high atmospheric humidity. This can sometimes be incorrectly interpreted as water leakage.

## **2. Controlling the heat pump (LCD)**







Not applicable.

## **3. Controlling the heat pump (LED)**

**Preparation before start-up**

- A) Inspection of the heat pump
- Check whether the outer appearance of the unit or piping system has been damaged during transportation.
  - Check that the ventilator fan does not touch any part of the unit.
- B) Verifying the electrical connections
- Check that the power supply complies with the specifications in this manual or on the label placed on the unit.
  - Check whether the power cabling is connected correctly and firmly according to the wiring diagram. Adequate grounding is required to protect against electrical shock.

### 3.1 Controller diagram

- A. : Switch heat pump on or off
- B. MODE: Select auto, heating or cooling mode.  
Corresponding indicator light will go on when selected
- C.  or : Press to change digits.
- D. : 'Timer start' setting button
- E. : 'Timer stop' setting button
- F. : Time setting button

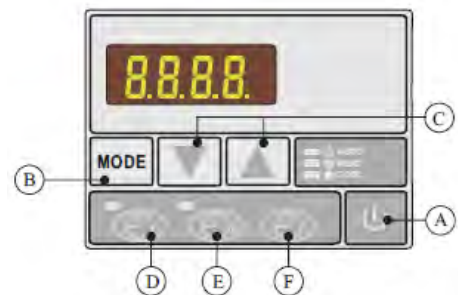

### 3.2 How to start heat pump

When connected with power, the controller will display the time. This means that the unit is in standby. Press  to start the heat pump. The controller display will now show the inlet water temperature.

**Please note : If the buttons are touched many times, the processor will stop working and you will be not able to change the mode. In this case turn off and then on the power to the heat pump.**

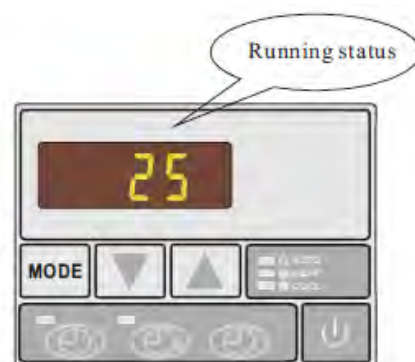
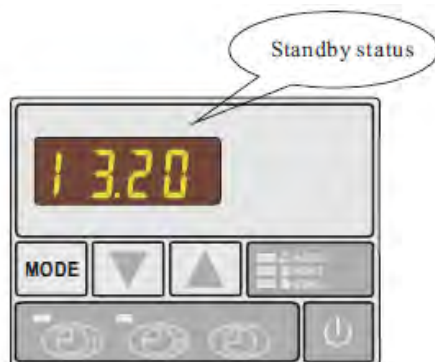

### 3.3 How to change mode

Press MODE to select auto, heating or cooling mode: the indicator light on the right side of the controller will indicate the mode selected.



### 3.4 How to set the desired water temperature

1. First select the desired mode: auto, heating or cooling
2. Regardless of whether the heat pump is running or on standby, press ▲ or ▼. The display will show the currently set water temperature of the selected mode with a flashing number: change the water temperature by moving ▲ or ▼ as required

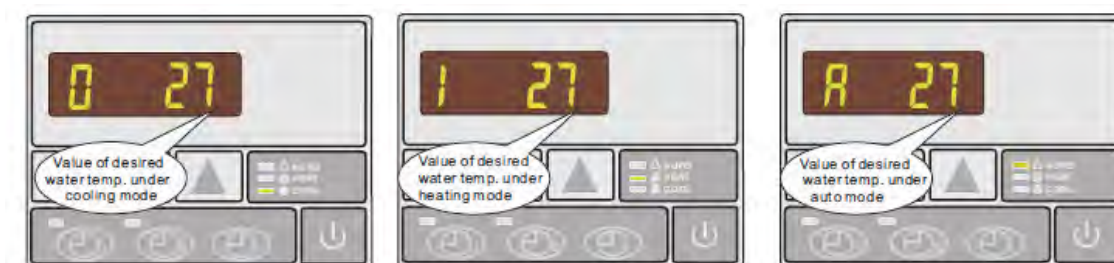

### 3.5 How to change parameter setting - ONLY FOR DEALERS

1. In standby status, press and hold MODE button for 5s, then use ▲ or ▼ to find parameters 0-A and measured values of current status B or F, both parameter and value will be blinking.
2. Press and hold ▲ and ▼ at the same time for 5 seconds continuously to activate parameter setting
3. Change value on setting until a BEEP is heard while display continues to indicate parameters by means of flashing values
4. Wait for 5 seconds to store the data automatically and return to standby status. Press  button to start the heat pump working.  
Check if the heat pump is in required mode- auto, cooling, heating.

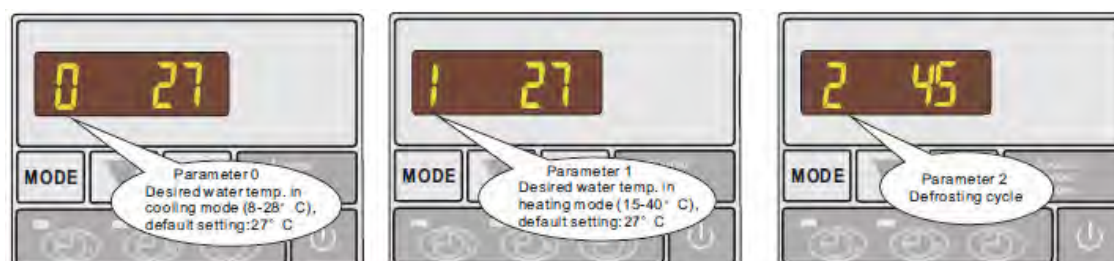

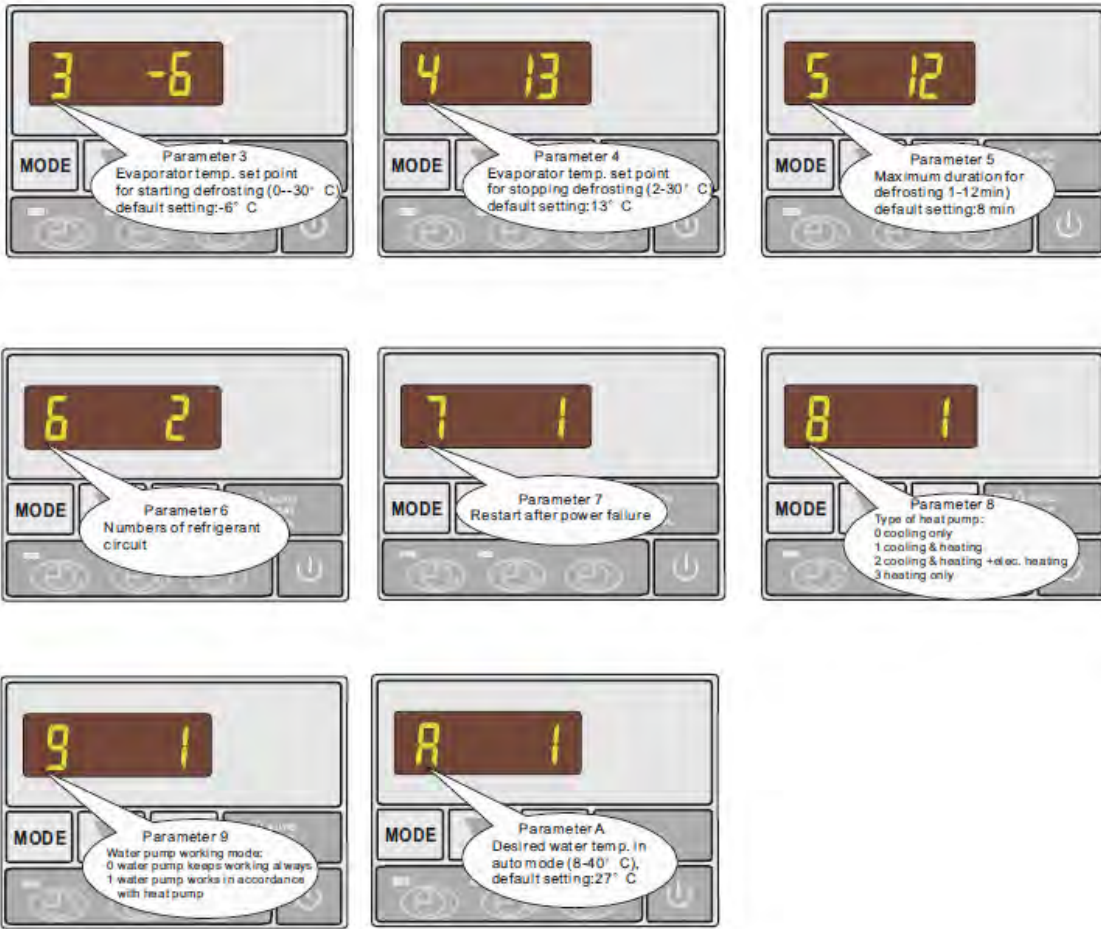

### 3.6 How to check parameter settings and measured values of current status

In standby or running status press ▲ or ▼ to find parameter 0-A and measured values of current status.

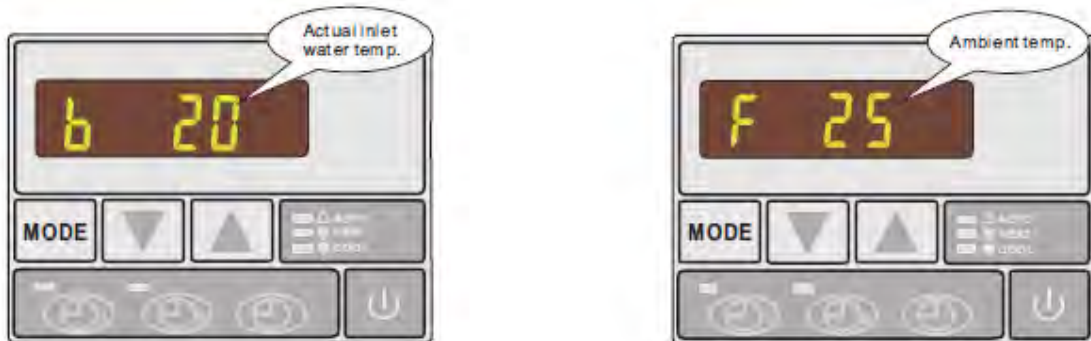





## Parameter table overview







Parameter	Definition	Range	Default	Remark
0	Desired water temperature in cooling mode	8~28℃	28℃	Ajusted by Technicians
1	Desired water temperature in heating mode	15~40℃	28℃	Ajusted by Technicians
2	Defrosting cycle	30~90Min	45Min	Ajusted by Technicians
3	Evaporator temperature set point for starting defrosting	-30 ~0℃	-6℃	Ajusted by Technicians
4	Evaporator temperature set point for stopping defrosting	2~30℃	12℃	Ajusted by Technicians
5	Maximum duration for defrosting	1~15Min	8Min	Ajusted by Technicians
6	Number of compressor in the system	1~2	1	Ajusted by Technicians
7	Restart after power failure	0~1	1 (Yes)	Ajusted by Technicians
8	Type: Cooling only 0/ Heating & cooling 1/ Heating & cooling + Auxiliary heating 2/ Heating only 3/	0~3	1	Ajusted by Technicians
9	Different working mode of water pump: water pump keeps working always 0/ water pump works in accordance with heat pump 1 /	0~1	0	Ajusted by Technicians
A	Desired water temperature in auto mode	8~40℃	30℃	Ajusted by Technicians
B	Actual inlet water temp.	-9~90℃		Measured Value
C	Actual outlet water temp.	-9~90℃		Measured Value
D	Coil temp. in system 1	-9~90℃		Measured Value
E	Coil temp. in system 2	-9~90℃		Measured Value
F	Ambient temp.	-9~90℃		Measured Value

## 3.7 How to set the clock

1. In standby, press : hour digits will flash to indicate that they can be modified by pressing ▲ or ▼
2. Press  again: minute digits will flash to indicate that they can be modified by pressing ▲ or ▼
3. Press  again for final confirmation of time setting

Once time has been set, LED display will show time when heat pump is on standby.



### 3.8 How to set timer start and timer stop

- Press  to activate 'timer start' setting: hour and minute digits will be flashing together.
- Press  again to modify the hour setting: the hour digits will flash meaning they are ready to be modified by pressing ▲ or ▼.
- Press  again to modify the minute setting: the minute digits will flash meaning they are ready to be modified by pressing ▲ or ▼.
- Press  to confirm setting - display will return to standby status. 'Timer start' green indicator light will light up to show the starting time has been set.
- Repeat the same procedure using  instead of  to set 'timer stop'. 'Timer stop' red indicator light will light up to show the stopping time has been set.

**Note:** 'timer start' and 'timer stop' can be set together or separately (i.e. it is possible to set 'timer start' only and then stop the unit manually or set 'timer stop' only and start the unit manually)



### 3.9 How to cancel 'timer start' and 'timer stop

Press  to activate 'timer start' or  to activate 'timer stop': the corresponding indicator light will be flashing. Press  to cancel 'timer start' or 'timer stop'.

### 3.10 Locking and unlocking the keypad

Except during parameter setting, press and hold ▲ or ▼ at the same time for 3 seconds: you will hear a BEEP and the keypad will be locked. To unlock, press and hold both buttons simultaneously again for 3 seconds.

## **4. Protection Systems**

### **4.1 Water flow switch**

The heat pump is equipped with a flow switch to ensure that it does not run when the filter pump is not working (and the water is not circulating).

This system prevents the heat pump from heating only the water present in the heat pump itself. The protection also stops the heat pump if water circulation is cut off or stopped.

### **4.2 Refrigerant gas high and low-pressure protection**

The high-pressure protection ensures that the heat pump is not damaged in case of over-pressurisation of the gas. The low-pressure protection emits a signal when refrigerant is escaping from the conduits and the unit cannot be kept running.

### **4.3 Overheating protection on the compressor**

This protection protects the compressor from overheating.

### **4.4 Automatic defrost control**

When the air is very humid and cold, ice may form on the evaporator. In such cases, a thin layer of ice appears that will grow increasingly bigger as long as the heat pump is running. When the temperature of the evaporator becomes too low, the automatic defrost control will be activated: this will reverse the heat pump cycle so that hot refrigerant gas is sent through the evaporator for a brief period of time to defrost it.

### **4.5 Temperature difference between in-flowing and out-flowing water**

During normal operation of the heat pump, the temperature difference between the water flowing into and out of the unit will be approximately 1 to 2°C. In the event that the pressure switch does not work and that the water stops circulating, the temperature probe monitoring the out-flowing water will always detect a rise in temperature. As soon as the temperature difference between in-flowing and out-flowing water exceeds 13°C, the heat pump will be automatically turned off.

### **4.6 Low temperature cut-off**

If, during cooling, the temperature of the out-flowing water reaches or drops below 5°C, the heat pump will turn itself off until the water temperature reaches or exceeds 7°C.

### **4.7 Anti-frost protection during winter**

This protection can only be activated if the heat pump is in STANDBY.

### **4.8 First anti-frost protection**

If the filter pump is controlled by the heat pump (regardless of the value set for parameter 9), when the water temperature is between 2 and 4°C, and the air temperature is lower than 0°C, the filter pump will be automatically turned on to prevent the water in the pipes from freezing. This protection is deactivated when the temperature rises again.

### **4.9 Second anti-frost protection**



If the water temperature drops further, i.e. below 2°C (during long periods of frost), the heat pump will also start running to heat the water until the temperature reaches approximately 3°C. Once this temperature is reached, the heat pump will stop but the anti-frost protection will remain active until conditions change.

## 5. Recommendations

### 5.1 Swimming pool water chemistry

Special attention should be paid to the chemical balance of the pool water. The pool water values should always stay within the following limits:

	Min.	Max.
pH	7,0	7,4
Free Chlorine (mg/l)	-	1,2
TAC (mg/l)	50	120
Salt (g/l)	-	3

#### **Important: failure to comply with these limits will invalidate the warranty**

**Note: exceeding one or several limits can damage the heat pump beyond repair. Always install water-treatment equipment (e.g. chemical dosing systems) after the water outlet of the heat pump, especially if the chemicals are automatically added to the water (e.g. automatic chemical dosing systems).**

**A check valve should also be installed between the outlet of the heat pump and the water-treatment equipment to prevent products from flowing back into the heat pump if the filter pump stops.**

### 5.2 Heat pump winterizing

#### **Important: failure to take necessary precautions for winterising can damage the heat pump, which will invalidate the warranty.**

The heat pump, filter pump, filter and conduits must be protected in areas where the temperature can drop below freezing point. Evacuate all water from the heat pumps as follows:

1. Interrupt the electrical power supply to the heat pump
2. Close the water supply to the heat pump: completely close valves 2 and 3 of the by-pass
3. Disconnect water inlet and outlet coupling fittings of the heat pump and let the water drain out of the unit
4. Loosely reattach water inlet and outlet coupling fittings of the heat pump in order to prevent dirt from getting into the conduits.

**Note: these precautions should be taken if you choose to use the built-in anti-frost protection.**

### 5.3 Restarting the pump after winter

If you emptied the heat pump for winterising, follow the steps below to restart it in spring:

1. First check that there is no dirt in the conduits and that there are no structural problems
2. Check that the water inlet and outlet coupling fittings are adequately fastened to the heat pump
3. Start the filter pump to start the water flow to the heat pump. Set the by-pass again.
4. Reconnect the electrical power supply to the heat pump and turn it ON.

#### 5.4 Check-up

Our heat pumps have been built and developed to last if they have been installed correctly and can operate in normal conditions. Regular check-ups are important if you want your heat pump to function efficiently for many years. Below are some recommendations to ensure optimal working conditions for your heat pump.

1. Make sure that the service panel is easily accessible.
2. Keep the area surrounding the heat pump free of organic waste.
3. Prune any vegetation around the heat pump so that there is sufficient free space around the pump.
4. Remove any water sprinklers that are near the heat pump as they could cause damage to it.
5. Prevent rain from running directly onto the heat pump from a roof. Install proper drainage.
6. Do not use the heat pump if it has been flooded. Immediately contact a qualified technician to inspect the heat pump and repair it should it be necessary to do so.

Condensation can occur when the heat pump is running. This condensation water can flow away through an opening in the base pan of the unit. The amount of condensation water will increase when atmospheric humidity is high. Remove any dirt that could impede the discharge of the condensation. 10 to 20 litres of condensation water can be produced while the unit is running. If more condensation is produced, stop the heat pump and wait for one hour before checking for leaks in the conduits.

**Note: a quick way to verify that the water running through the condensation is indeed condensation is to shut off the unit and keep the pool pump running. If the water stops running out of the condensation drain, it is condensation. AN EVEN QUICKER WAY is to TEST THE DRAIN WATER FOR CHLORINE. If no chlorine is detected, the drain water is a result of condensation.**

Also make sure that the air inlet and exhaust passages are free, and prevent exhaust air from immediately re-entering the unit through the inlet.

**Dubai,**

6. Maintenance and Inspection

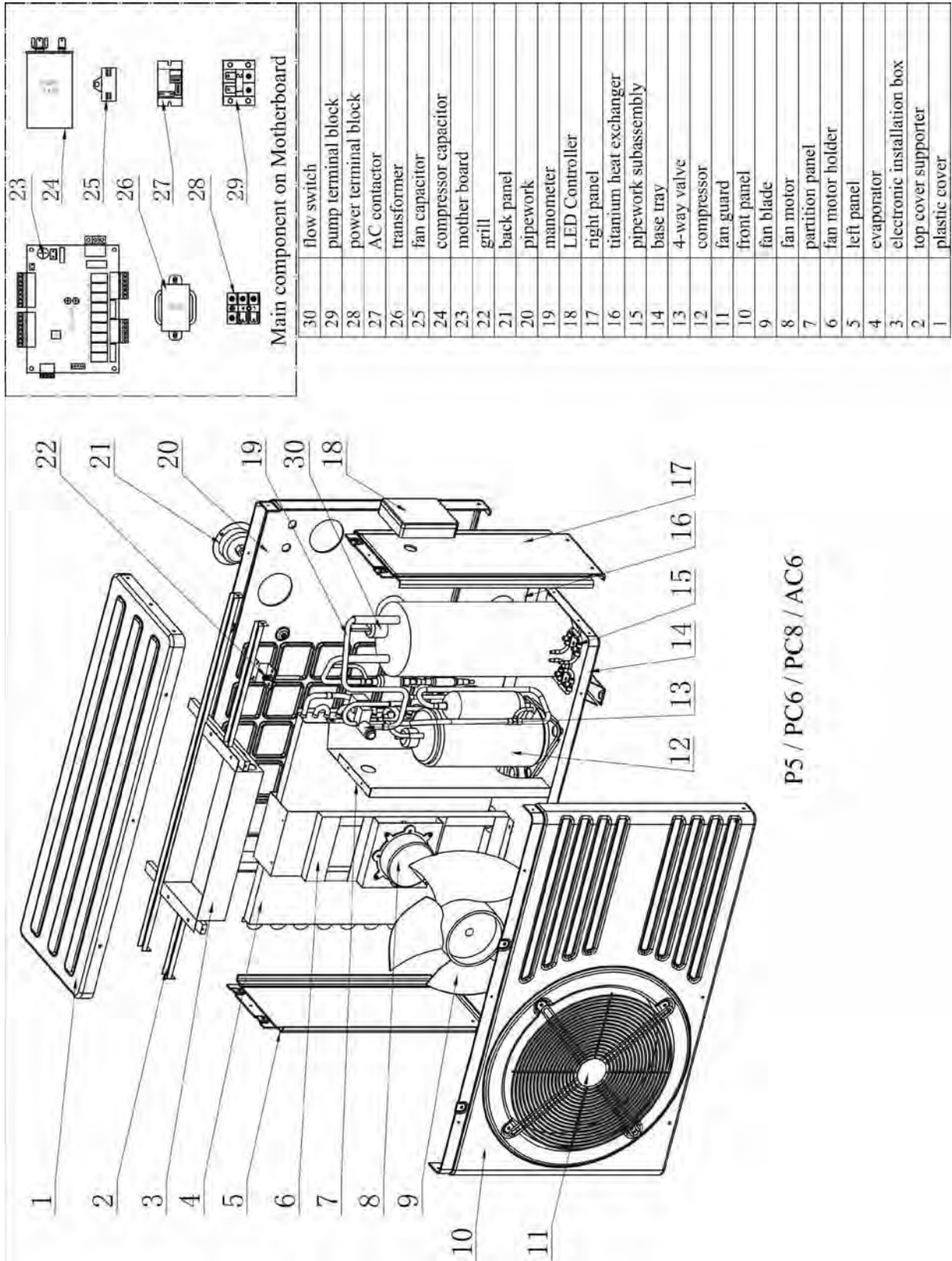

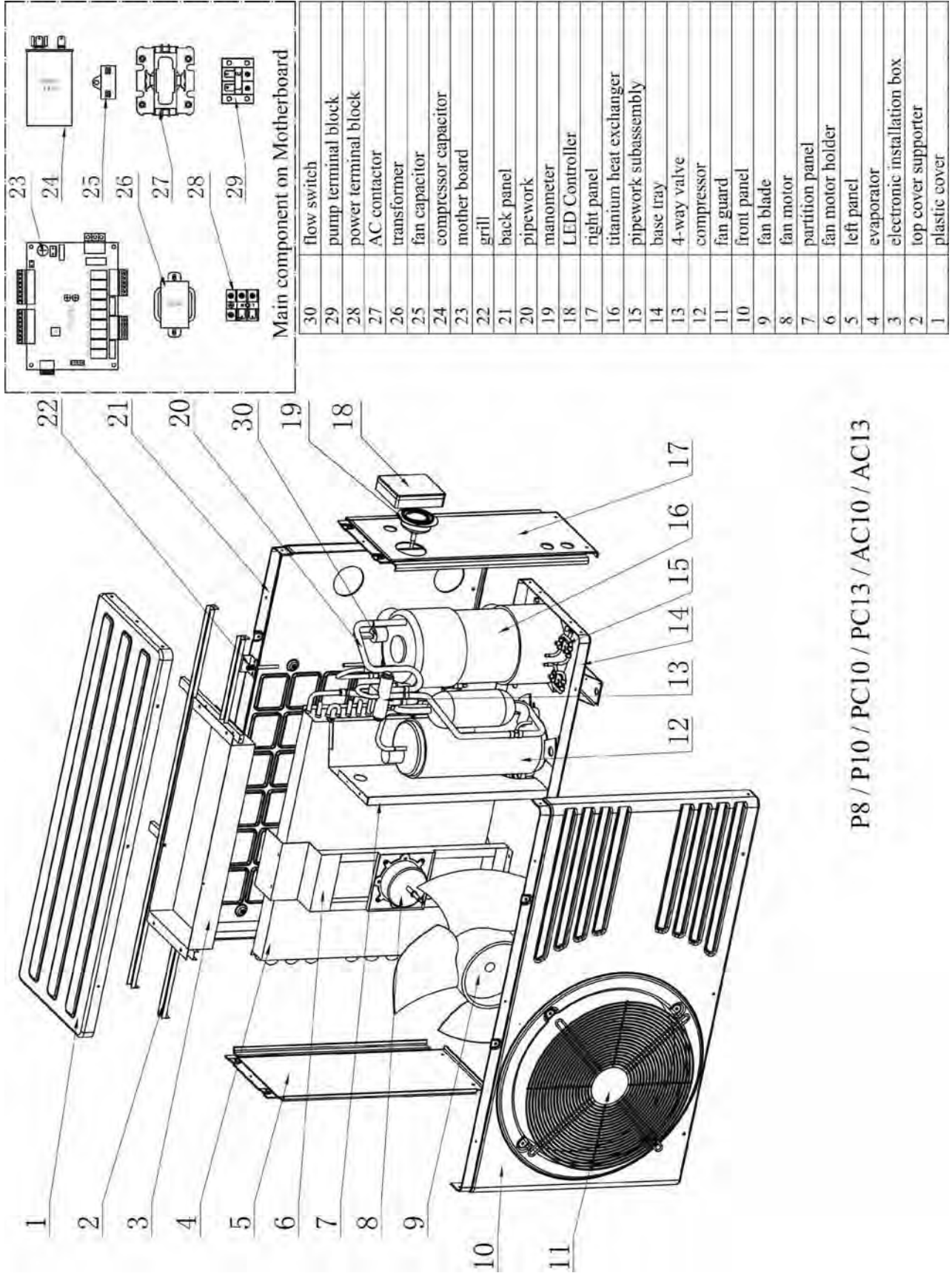

P8 / P10 / PC10 / PC13 / AC10 / AC13

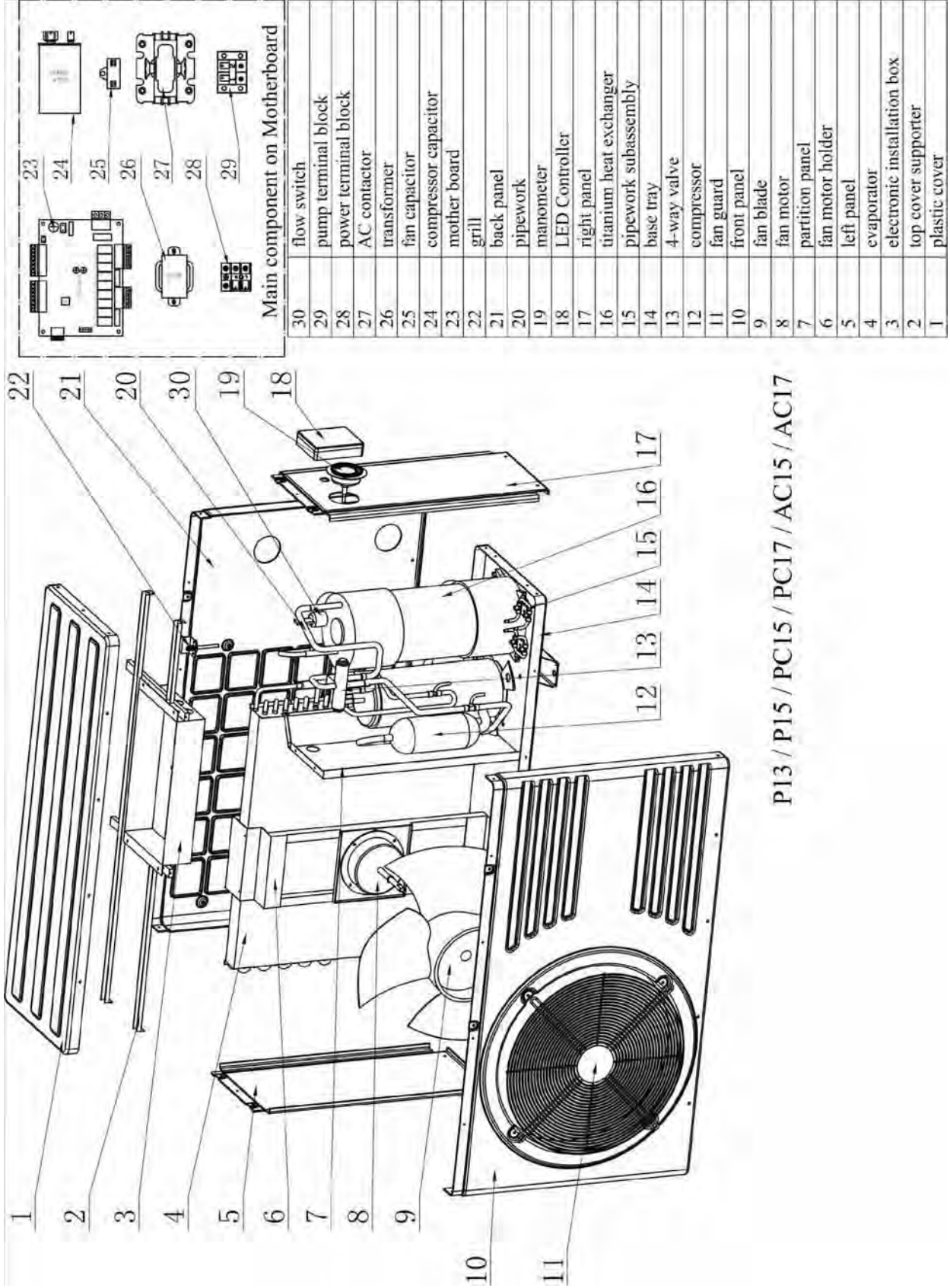

P13 / P15 / PC15 / PC17 / AC15 / AC17



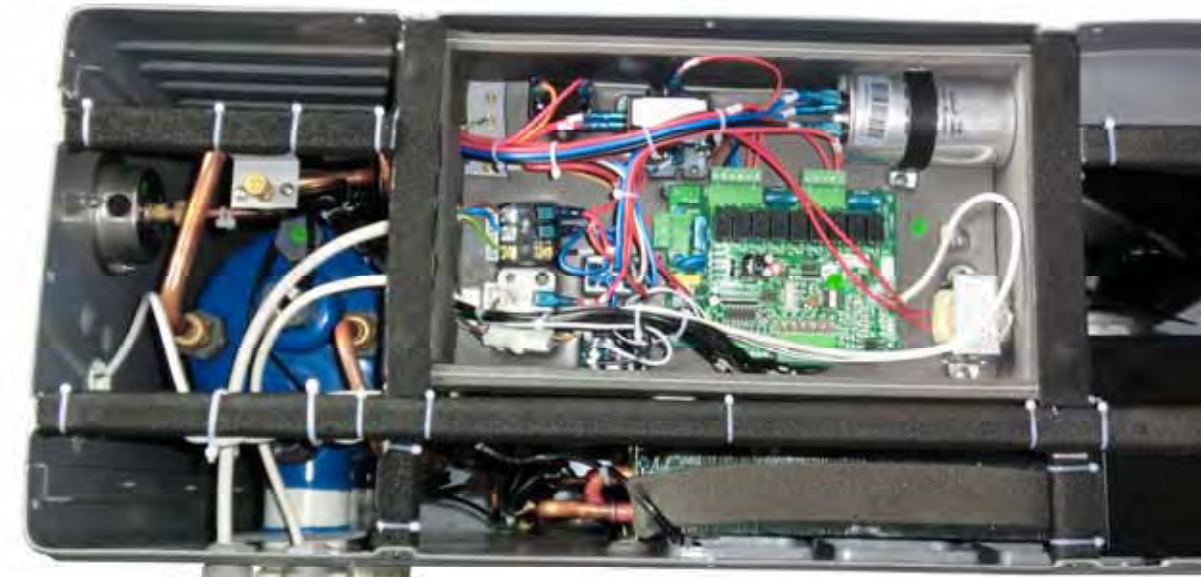

Power in 230V →  
Power out 230V  
to filter pump →

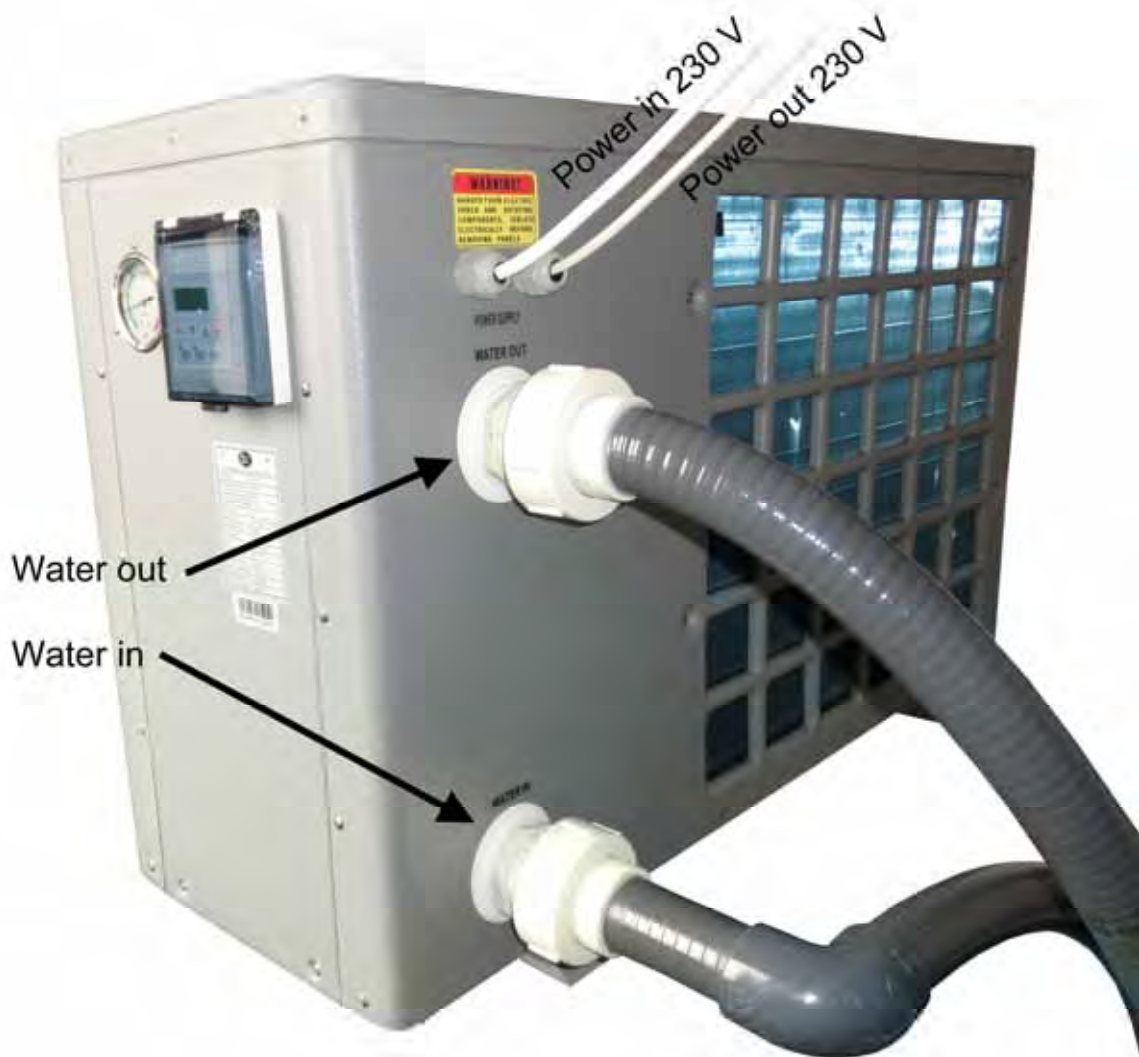

Water out →  
Water in →





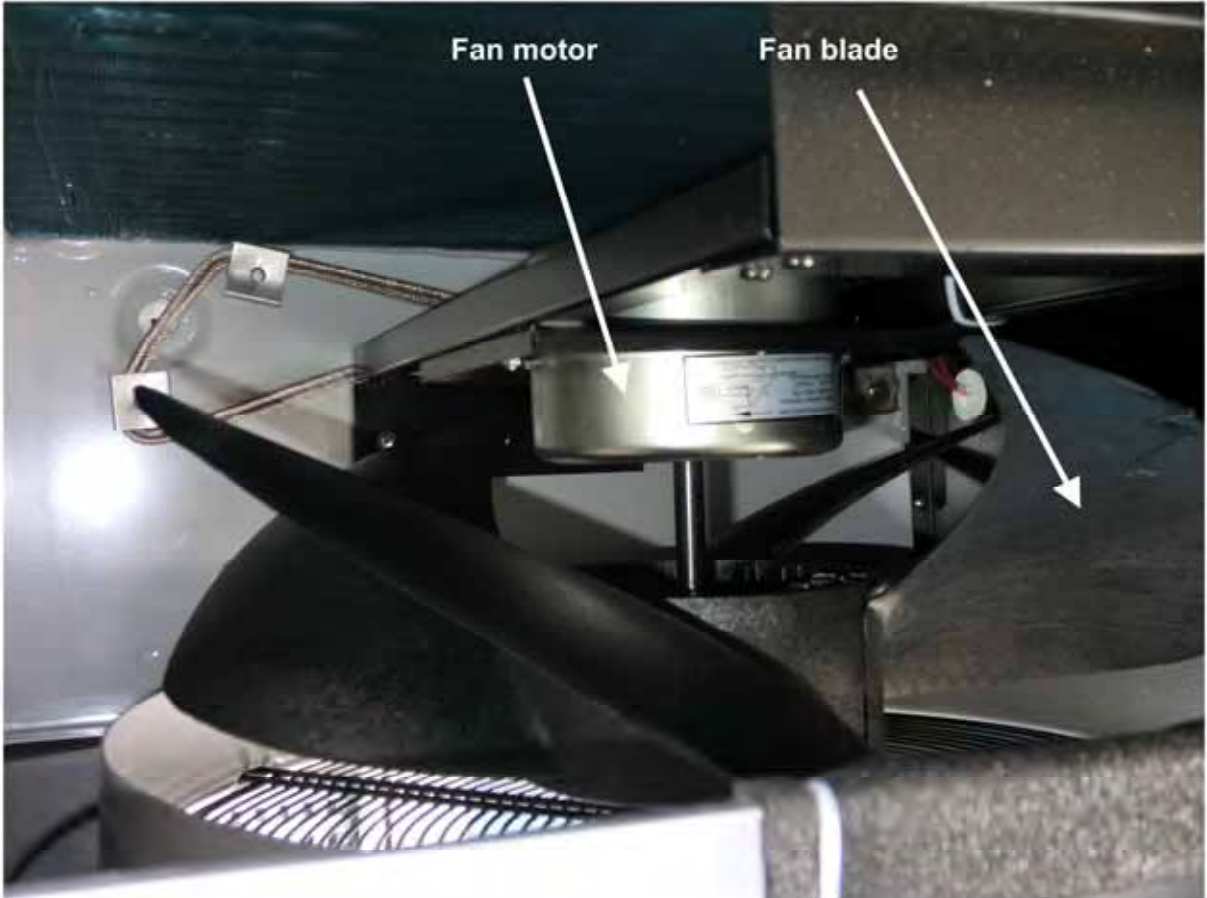



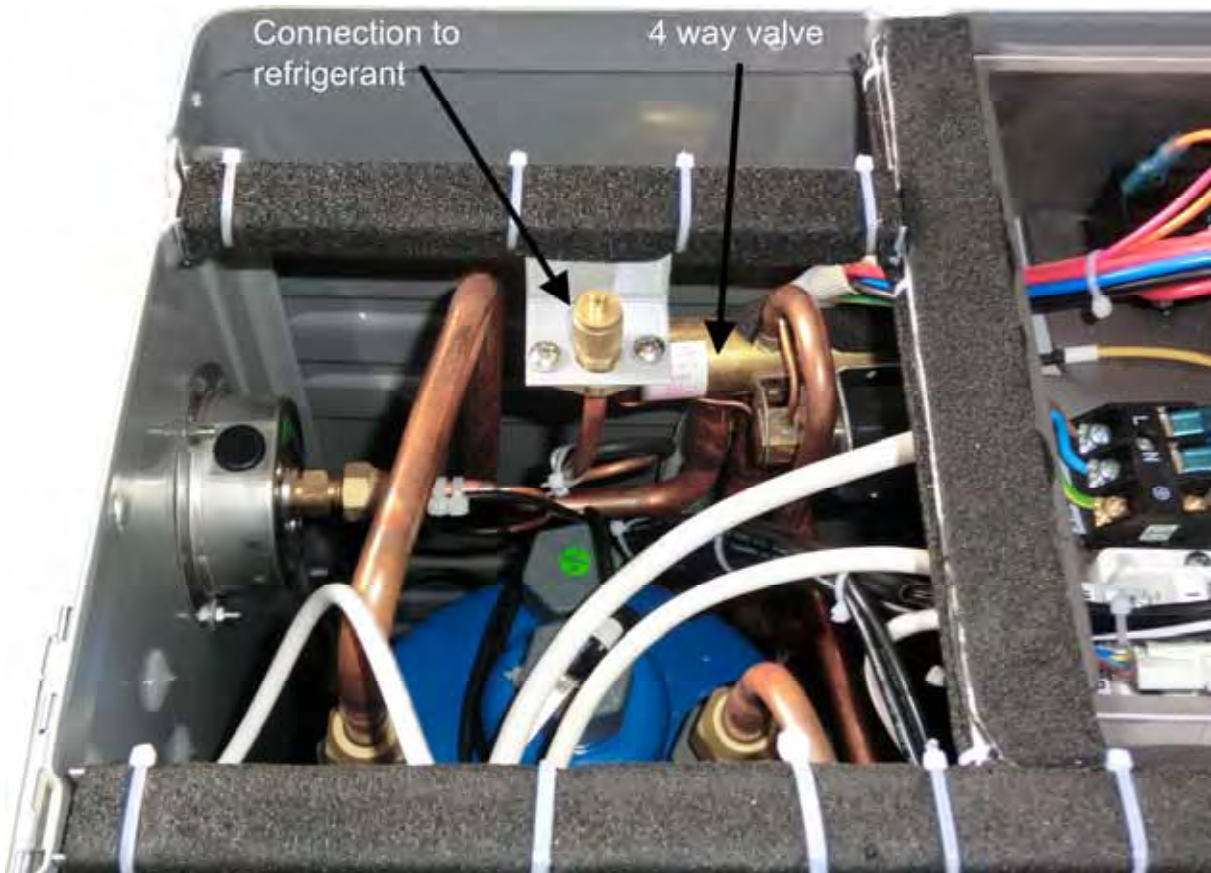
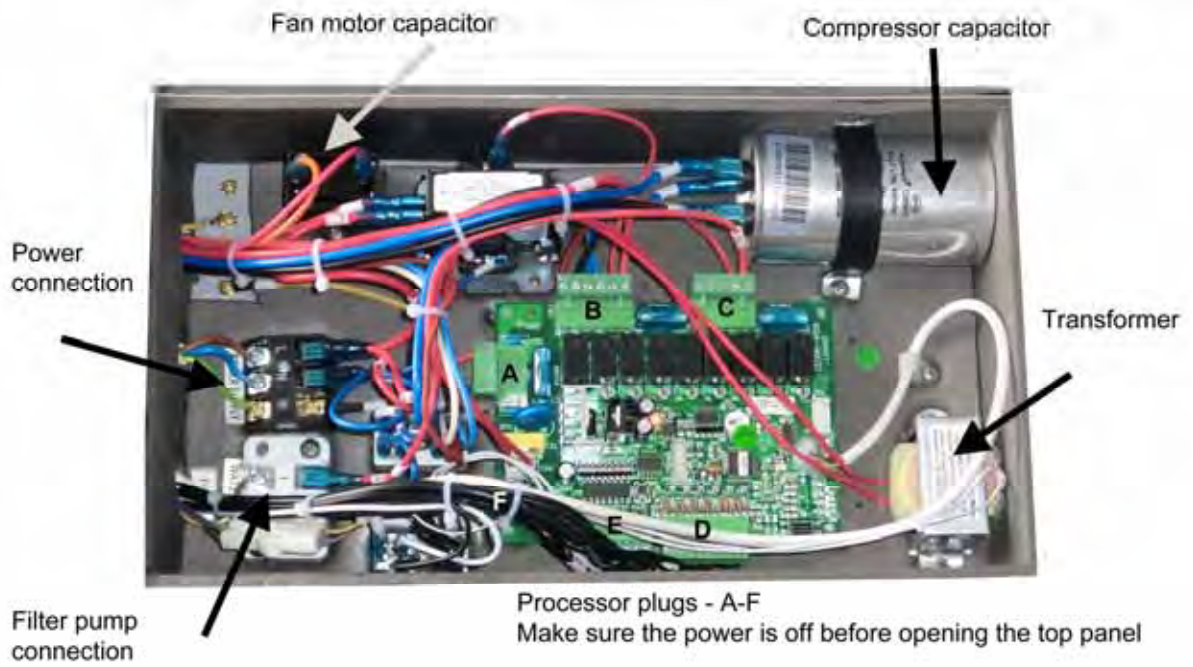

### 6.1 Maintenance

- Check the water inlet and drainage often. The water and air inflow into the system should be sufficient so that its performance and reliability are not compromised. Clean the pool filter regularly to avoid damage to the unit caused by clogging of the filter.
- Sufficient space should be left around the unit and the area should be well ventilated. Clean the sides of the heat pump regularly to maintain optimal heat exchange conditions and to save energy.
- Check that all the processes in the unit are operational and pay special attention to the operating pressure of the refrigerant system.
- Check the power supply and cable connections regularly. Should the unit begin to function abnormally or should you notice a smell coming from an electrical component, arrange for timely repair or replacement.
- Empty the water from the unit if you will not use it for a long time. You should check all parts of the unit thoroughly and completely fill the system with water before turning it on again after such a prolonged period without use.

## 6.2 Troubleshooting guide

Incorrect installation may result in an electrical charge that could lead to death or serious injury of users, installers or others by electrical shock, and it may also cause damage to property.

**DO NOT** attempt to modify the internal configuration of the heat pump.

1. Keep your hands and hair clear of the fan blades to avoid injury.
2. If you are not familiar with your pool filtration system and heat pump:
  - a. **Do not** attempt to carry out any adjustment or service without consulting your dealer, pool professional or air conditioning contractor.
  - b. Read the entire installation manual before attempting to use, service or make adjustments to the unit.
  - c. Start the heat pump at least 24 hours after its installation in order to prevent damage to the compressor.

**Note:** Switch off the power before carrying out any maintenance or repairs

**IMPORTANT REMARK:** if a malfunction cannot be resolved immediately, in order to analyse the problem we will need to know the message (error code) that is displayed on the controller as well as the values for the settings (parameters 00-10 for LCD display and parameters 0-A for LED display). We also need to know the status of the heat pump (ambient temperature, water inlet / outlet temperature and system coil temperature) just before the failure or, if this is not possible, just after it.

Please keep this information at hand when calling customer service.

On the following pages you will find an overview of the different types of failure problems that can occur together with instructions on how to solve them.

Problem:	the heat pump doesn't work
Observation:	the screen does not light up and the fan/compressor doesn't make a sound

Possible cause	Solution
No electrical power supply	Check power supply (wiring, fuses,.....)

<b>Problem :</b>	the heat pump works normally but there is no or insufficient heating	
<b>Observation:</b>	The screen displays the temperature but no error codes	
Possible cause	Solution	
1. Insufficient capacity of the heat pump in proportion to the size of the swimming pool	1. Install a larger sized model or an extra heat pump. Cover the pool to limit heat loss	
2. The compressor works but the fan doesn't	2. Check the electrical wiring of the fan. Replace the condenser or the fan motor if necessary.	
3. The fan works but the compressor doesn't	3. Check the electrical wiring of the compressor. Replace the condenser or the compressor if necessary.	
4. The heat pump has not been placed in an optimal location	4. Ensure sufficient air circulation (see manual for details)	
5. Faulty temperature setting	5. Set the correct temperature	
6. By-pass not installed	6. Have the by-pass installed by the installer	
7. Massive ice formation on the evaporator	7. Have the settings for automatic defrost control checked by the installer	
8. Not enough refrigerant	8. Have the heat pump checked by a refrigeration technician	

<b>Problem:</b>	The heat pump works normally but the water is cooling down instead of heating up	
<b>Observation:</b>	The screen displays the temperature but no error codes	
Possible cause	Solution	
1.The wrong mode has been selected	1.Verify the parameters, select the correct mode	
2. The controller is out of order	2. Check the voltage in the electrical wiring to the 4-way valve. If no electric potential is measured, replace the controller	
3. The 4-way valve is out of order	3. Check the voltage in the electrical wiring to the 4-way valve. If electric potential is measured, replace the coil. If the problem persists, have the heat pump checked by a refrigeration technician	

<b>Problem:</b>	the heat pump doesn't stop	
<b>Observation:</b>	the screen displays the temperature but no error codes	
Possible cause	Solution	
1.Wrong setting of parameters	1.Check the set parameters and adjust them if necessary (settings just above the capacity of the heat pump)	
2. Pressure switch out of order	2. Check operation of the pressure switch by turning off the filter pump and restarting it. If the heat pump doesn't react to this, the pressure switch must be adjusted or replaced.	
3. Electrical failure	3. Contact your installer	

<b>Problem:</b>	water leak	
<b>Observation:</b>	There is a large amount of water under the heat pump	

Possible cause	Solution
1. Condensation due to atmospheric humidity	1. No action required
2. Water leak	2. Try to locate the leak and check for the presence of chlorine in the water. If there is chlorine, the heat pump must be temporarily replaced while it is being repaired.

<b>Problem:</b>	abnormal amount of ice formed on the evaporator	
<b>Observation:</b>	the evaporator is for the most part covered in ice	
Possible cause	Solution	
1. Insufficient air inflow	1. Check the location of the heat pump and remove any dirt that could be present on the evaporator	
2. High water temperature	2. If the pool water is already quite hot (warmer than 29°C), the probability of ice formation increases. Lowering the set temperature is a possible option	
3. Incorrect setting of automatic defrost control	3. Check the setting of the defrosting function together with your installer.	
4. The 4-way valve is out of order	4. Check the voltage in the electrical wiring to the 4-way valve. If electric potential is measured, replace the coil. If the problem persists, have the heat pump checked by a refrigeration technician.	
5. Not enough refrigerant	5. Have the heat pump checked by a refrigeration technician.	

### 6.3 Overview of failure code on Display (LCD controller) – not applicable

### 6.4 Overview of failure code on Display (LED controller)

Wire controller	Protection/Failure	Check	Solution
PP01/PP1	Inlet water temp. sensor failure	1. Check the connection of inlet water sensor. 2. Check if the sensor is broken.	1. Reconnect the sensor. 2. Replace the sensor.
PP02/PP2	Outlet water temp. sensor failure	1. Check the connection of outlet water sensor. 2. Check if the sensor is broken.	1. Reconnect the sensor. 2. Replace the sensor.
PP03/PP3	Coil 1 temp. sensor failure	1. Check the connection of coil 1 temperature sensor. 2. Check if the sensor is broken.	1. Reconnect the sensor. 2. Replace the sensor.
PP04/PP4	Coil 2 temp. sensor failure	1. Check the connection of coil 2 temperature sensor. 2. Check if the sensor is broken.	1. Reconnect the sensor. 2. Replace the sensor.
PP05/PP5	Ambient temp. sensor failure	1. Check the connection of ambient temperature sensor. 2. Check if the sensor is broken.	1. Reconnect the sensor. 2. Replace the sensor.
PP06/PP6	Protection for excessive temp. difference between water inlet & outlet	1. Check if there is any blockage in the water circuit. 2. Check if the water flow volume is enough. 3. Check if the water pump is working.	1. Remove the cause of the blockage. 2. Increase the water flow volume. 3. Repair or replace the water pump.
PP07/PP7	Anti-freeze protection for cooling	Refer to PP06.	Refer to PP06.
PP07/PP7	Winter anti-freeze protection I	No action required	
PP07/PP7	Winter anti-freeze protection II	No action required	
EE03/EE3	Water flow switch failure	1. Check if wiring connection of flow switch is in correct position. 2. Check water flow. 3. Check if flow switch is broken. 4. Check if water pump is working.	1. Reconnect the wiring. 2. Increase water flow. 3. Replace flow switch. 4. Repair or replace water pump.
EE04/EE4	High / Low pressure protection	1. Check if high or low pressure switch is broken. 2. Check if refrigerant level is low (for low pressure). 3. Ambient temp. and water inlet temp. is too low (for low pressure). 4. Check if there is a blockage in water circuit or if water flow is not enough (for high pressure). 5. Check if there is a blockage in refrigerant circuit (for high pressure).	1. Replace pressure switch. 2. Fill up with enough refrigerant. 3. Decrease water flow. 4. Remove cause of blockage or increase water flow. 5. Send heat pump to dealer for detailed check.
EE05/EE5	Failure of excessive temp. difference protection between water inlet & outlet	1. Check if there is enough water flow volume. 2. Check if inlet / outlet water temp. sensor is working.	1. Increase water flow. 2. Replace sensor.
No display	Defrosting		
EE08/EE8	Communication failure	Check the connection	Reconnect the connection wire.

### 6.5 Failure code table for Chiller-300 three-phase



Wire controller	Protection/Failure	Check	Solution
PP01/PP1	Inlet water temp. sensor failure	1. Check the connection of inlet water sensor. 2. Check if the sensor is broken.	1. Reconnect the sensor. 2. Replace the sensor.
PP02/PP2	Outlet water temp. sensor failure	1. Check the connection of outlet water sensor. 2. Check if the sensor is broken.	1. Reconnect the sensor. 2. Replace the sensor.
PP03/PP3	Coil 1 temp. sensor failure	1. Check the connection of coil 1 temperature sensor. 2. Check if the sensor is broken.	1. Reconnect the sensor. 2. Replace the sensor.
PP04/PP4	Coil 2 temp. sensor failure	1. Check the connection of coil 2 temperature sensor. 2. Check if the sensor is broken.	1. Reconnect the sensor. 2. Replace the sensor.
PP05/PP5	Ambient temp. sensor failure	1. Check the connection of ambient temperature sensor. 2. Check if the sensor is broken.	1. Reconnect the sensor. 2. Replace the sensor.
PP06/PP6	Protection for excessive temp. difference between water inlet & outlet	1. Check if there is any blockage in the water circuit. 2. Check if the water flow volume is enough. 3. Check if the water pump is working.	1. Remove the cause of the blockage. 2. Increase the water flow volume. 3. Repair or replace the water pump.
PP07/PP7	Anti-freeze protection for cooling	Refer to PP06.	Refer to PP06.
PP07/PP7	Winter anti-freeze protection I	No action required	
PP07/PP7	Winter anti-freeze protection II	No action required	
EE01/EE1	High pressure protection	1. Check if high pressure switch is broken. 2. Check if there's a blockage in the water circuit or if water flow is not enough. 3. Check if there is a blockage in the refrigerant circuit.	1. Replace new high pressure switch. 2. Fill up with enough refrigerant. 3. Remove cause of blockage or increase water flow. 4. Send heat pump to dealer for detailed check.
	Low pressure protection	1. Check if low pressure switch is broken. 2. Check if refrigerant level is low. 3. Ambient temp. and water inlet temp. is too low.	1. Replace new low pressure switch. 2. Fill up with enough refrigerant. 3. Send heat pump to dealer for detailed check.
EE02/EE2	Malfunctions of system 2	Fault in system 2	1. Check all protection points in system 2.
EE03/EE3	Water flow switch failure	1. Check if wiring connection of flow switch is in correct position. 2. Check if there is enough water flow. 3. Check if flow switch is broken. 4. Check if water pump is working.	1. Reconnect the wiring. 2. Increase water flow. 3. Replace flow switch. 4. Repair or replace water pump.

EE04/EE4	High / Low pressure protection	<ol style="list-style-type: none"> <li>1. Check if high or low pressure switch is broken.</li> <li>2. Check if refrigerant level is low (for low pressure).</li> <li>3. Ambient temp. and water inlet temp. is too low (for low pressure).</li> <li>4. Check if there is a blockage in water circuit or if water flow is not enough (for high pressure).</li> <li>5. Check if there is a blockage in refrigerant circuit (for high pressure).</li> </ol>	<ol style="list-style-type: none"> <li>1. Replace pressure switch.</li> <li>2. Fill up with enough refrigerant.</li> <li>3. Decrease water flow.</li> <li>4. Remove cause of blockage or increase water flow.</li> <li>5. Send heat pump to dealer for detailed check.</li> </ol>
EE05/EE5	Failure of excessive temp. difference protection between water inlet & outlet	<ol style="list-style-type: none"> <li>1. Check if there is enough water flow volume.</li> <li>2. Check if inlet / outlet water temp. sensor is working.</li> </ol>	<ol style="list-style-type: none"> <li>1. Increase water flow.</li> <li>2. Replace sensor.</li> </ol>
No display	Defrosting		
EE08/EE8	Communication failure	Check the connection	Reconnect the connection wire.





Wire Controller	Protect-300 LED Code	Protect/Failure
EE01	38	System 1 Low pressure protection
EE01	68	System 1 High pressure protection
EE01	58	System 1 Over current protection
EE01	18	System 1 Refrigerant anti-freeze protection
EE01	48	System 1 Exhaust gas over-high temp. protection
EE01	28	System 1 Refrigerant leakage protection
EE01	78	System 1 Refrigerant in temp sensor failure
EE01	88	System 1 Refrigerant out temp. sensor failure
EE01	98	System 1 Exhaust gas temp. sensor failure
EE02	83	System 2 Low pressure protection
EE02	86	System 2 High pressure protection
EE02	85	System 2 Over current protection
EE02	81	System 2 Refrigerant anti-freeze protection
EE02	84	System 2 Exhaust gas over-high temp. protection
EE02	82	System 2 Refrigerant leakage protection
EE02	87	System 2 Refrigerant in temp sensor failure
EE02	88	System 2 Refrigerant out temp. sensor failure
EE02	89	System 2 Exhaust gas temp. sensor failure
EE04	EE	Wrong phase or lack of phase



## 6.7 Failure code table for general PCB (single-system)

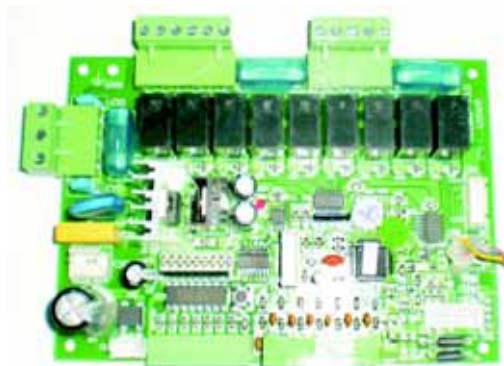

Wire controller	Protection/Failure	Check	Solution
PP01/PP1	Inlet water temp. sensor failure	1. Check the connection of inlet water sensor. 2. Check if the sensor is broken.	1. Reconnect the sensor. 2. Replace the sensor.
PP02/PP2	Outlet water temp. sensor failure	1. Check the connection of outlet water sensor. 2. Check if the sensor is broken.	1. Reconnect the sensor. 2. Replace the sensor.
PP03/PP3	Coil temp. sensor failure	1. Check the connection of coil temperature sensor. 2. Check if the sensor is broken.	1. Reconnect the sensor. 2. Replace the sensor.
PP05/PP5	Ambient temp. sensor failure	1. Check the connection of ambient temperature sensor. 2. Check if the sensor is broken.	1. Reconnect the sensor. 2. Replace the sensor.
PP06/PP6	Protection for excessive temp. difference between water inlet & outlet	1. Check if there is any blockage in the water circuit. 2. Check if the water flow volume is enough. 3. Check if the water pump is working.	1. Remove the cause of the blockage. 2. Increase the water flow volume. 3. Repair or replace the water pump.
PP07/PP7	Anti-freeze protection for cooling	Refer to PP06.	Refer to PP06.
PP07/PP7	Winter anti-freeze protection I	No action required	
PP07/PP7	Winter anti-freeze protection II	No action required	
EE01/EE1	High pressure protection	1. Check if high pressure switch is broken 2. Check if there's a blockage in the water circuit or if water flow is not enough. 3. Check if refrigerant circuit jam.	1. Replace with new high pressure switch. 2. Fill up with enough refrigerant. 3. Remove cause of blockage or increase water flow. 4. Send heat pump to dealer for detailed check.
EE06/EE6	Low pressure protection	1. Check if low pressure switch is broken. 2. Check if refrigerant level is low. 3. Ambient temp. and water inlet temp. is too low.	1. Replace with new low pressure switch. 2. Fill up with enough refrigerant. 3. Send heat pump to dealer for detailed check.
EE03/EE3	Water flow switch failure	1. Check if wiring connection of flow switch is in correct position. 2. Check if there is enough water flow. 3. Check if flow switch is broken. 4. Check if water pump is working.	1. Reconnect the wiring. 2. Increase water flow. 3. Replace flow switch. 4. Repair or replace water pump.
EE04/EE4	Order of phases incorrect (only for 3 phase model)	Order of phases incorrect	Reconnect the phases in right order.
EE05/EE5	Failure of excessive temp. difference between water inlet & outlet	1. Check if there is enough water flow volume. 2. Check if inlet / outlet water temp. sensor is working.	1. Increase water flow. 2. Replace sensor.

No display	Defrosting		
EE08/EE8	Communication failure	Check the connection	Reconnect the connection wire.

**6.8 Failure code table for general PCB (dual-system) – not applicable**

**7. Name plate & wiring diagram**

**7.1 Name plate - not applicable**

**7.2 Wiring Diagram – not applicable**